



# SB3628

## Datasheet

### TK MCU Series

Revision 1.0

July 2015

ENE RESERVES THE RIGHT TO AMEND THIS DOCUMENT WITHOUT NOTICE AT ANY TIME. ENE ASSUMES NO RESPONSIBILITY FOR ANY ERRORS APPEAR IN THE DOCUMENT, AND ENE DISCLAIMS ANY EXPRESS OR IMPLIED WARRANTY, RELATING TO SALE AND/OR USE OF ENE PRODUCTS INCLUDING LIABILITY OR WARRANTIES RELATING TO FITNESS FOR A PARTICULAR PURPOSE, OR INFRINGEMENT OF ANY PATENTS, COPYRIGHTS OR OTHER INTELLECTUAL PROPERTY RIGHTS.

#### Headquarters

4F-1, No.9, Prosperity Rd.,  
Science-based Industrial Park,  
Hsinchu City, Taiwan, R.O.C

TEL: 886-3-6662888

FAX: 886-3-6662999

<http://www.ene.com.tw>

## Revision History

Version	Content	Date
V1.0	Initial release	2015/07

CONFIDENTIAL

## TABLE OF CONTENT

<b>1. GENERAL DESCRIPTION</b> .....	<b>1</b>
<b>1.1 OVERVIEW</b> .....	<b>1</b>
<b>1.2 CHARACTERISTICS</b> .....	<b>1</b>
<b>1.3 SELECTION GUIDE</b> .....	<b>1</b>
<b>1.4 APPLICATION</b> .....	<b>1</b>
<b>2 PINS ASSIGNMENT AND DESCRIPTION</b> .....	<b>2</b>
<b>2.1 PIN ASSIGNMENT</b> .....	<b>2</b>
<b>2.2 PIN DESCRIPTION</b> .....	<b>3</b>
<b>3. APPLICATION CIRCUIT</b> .....	<b>4</b>
<b>3.1 TYPICAL APPLICATION</b> .....	<b>4</b>
<b>3.2 CIRCUIT ELEMENTS PARAMETERS</b> .....	<b>5</b>
<b>3.3 APPLICATION EXAMPLE</b> .....	<b>6</b>
<b>4. COVER SELECTION AND SENSITIVITY ADJUSTMENT</b> .....	<b>8</b>
<b>4.1 COVER TYPE SELECTION (OTP4)</b> .....	<b>8</b>
<b>4.2 SENSITIVITY ADJUSTMENT (OPT3/OPT2/OPT1)</b> .....	<b>8</b>
<b>4.3 STANDARDS OF SENSITIVITY TEST BY COPPER STICK</b> .....	<b>8</b>
<b>5. TRANSMISSION FORMAT FOR DATA DISPLAY COMMAND</b> .....	<b>9</b>
<b>5.1 COMMAND CONFIGURATION</b> .....	<b>9</b>
<b>5.2 CORRESPONDING TABLE FOR DISPLAY MODE CONFIGURATION</b> .....	<b>9</b>
<b>5.3 CORRESPONDING TABLE FOR DATA CONFIGURATION</b> .....	<b>10</b>
<b>5.4 CORRESPONDING TABLE FOR DISPLAY CONTROL CONFIGURATION</b> .....	<b>10</b>
<b>5.5 CORRESPONDING TABLE FOR ADDRESS CONFIGURATION AND COMMAND FORMAT</b> .....	<b>10</b>
<b>5.6 CORRESPONDING TABLE OF DISPLAY DATA AND ADDRESS</b> .....	<b>11</b>
<b>6. READ FORMAT FOR TK STATUS DATA</b> .....	<b>12</b>
<b>6.1 TIME SEQUENCE OF READING TK STATUS</b> .....	<b>12</b>
<b>6.2 TOUCH KEY STATUS DATA</b> .....	<b>12</b>
<b>6.3 RELATED CONTROL REGISTERS</b> .....	<b>12</b>
<b>7. TRANSMISSION FORMAT OF SERIAL DATA</b> .....	<b>13</b>
<b>7.1 RECIEVE MODE (COMMAND/DATA INPUT)</b> .....	<b>13</b>
<b>7.2 READ MODE (DATA READ)</b> .....	<b>13</b>
<b>8. ELECTRICAL CHARATERISTICS</b> .....	<b>14</b>

8.1 ABSOLUTE RATING .....	14
8.2 NORMAL OPERATING RANGE.....	14
8.3 AC CHARACTERISTICS ( TA= -40~85 °C ) .....	14
8.4 DC CHARATERISTICS ( TA= 25 °C , VCC=5V).....	15
8.5 POWER-ON RESET CHARATERISTICS ( TA= 25 °C , VCC=5V) .....	15
8.6 SWITCH AND TIME SEQUENCE CHARATERISTICS ( TA= -40~85 °C ) .....	16
9. PACKAGING INFORMATION (28-SOP 300MIL).....	17
9.1 DIMENSIONS.....	17
9.2 MANUAL SOLDERING TEMPERATURE LIMITATIONS .....	17
9.3 PART NUMBER DESCRIPTIONS .....	17
9.4 PROCESSING TECHNIQUE DATA .....	18
10. IMPORTANT NOTICE .....	21
10.1 SOFTWARE .....	21
10.2 POWER SUPPLY .....	21
10.2.1 Internal Power (Internal LDO) .....	21
10.2.2 System Power VCC .....	21
10.2.3 Power Range and Requirements.....	22
10.3 PCB DESIGN .....	22
10.3.1 Power and Ground Design .....	22
10.3.2 PCB Layout .....	23
10.3.3 CEXT .....	25
10.3.4 Sensor pad and through hole for TK.....	26

## 1. General Description

### 1.1 Overview

SB3628 supports 6 CH touch keys (TK) and 7 Grid x 8 SEG LED driver. SB3628 is characterized with high SNR and anti-interference. SB3628 supports 1628 LED driver IC protocols and thus Master is able to communicate with SB3628 through serial ports (STB, CLK, DIO) and further control LED and access TK status. In short, SB3628 is a 2 in 1 IC with Touch Key and 1628 LED driver.

### 1.2 Characteristics

- ◇ Operating voltage range 2.7V~5.5V
- ◇ Support up to maximum 6 touch keys
- ◇ Support 1628 LED driver IC protocols
- ◇ 7 GRID × 8 SEG LED driver (8 interval grayscale)
- ◇ Able to adjust sensitivity through external resistor (8 intervals of sensitivity selection to suit different cover thickness)
- ◇ Able to select cover type through external resistor (acrylic or glass)
- ◇ High SNR/High Anti-interference touch key (able to adjust to different environment automatically)
- ◇ CMOS process, SOP28 package, compliant to RoHS

### 1.3 Selection Guide

Part Number	TK	Communication Port	LED Output	Package
SB3628	6 CH	Standard 1628 serial port (STB/CLK/DIO)	7 COM x 8 SEG	SOP28

### 1.4 Application

- ◇ Audio system
- ◇ Various small home appliances
- ◇ Various white brand applications
- ◇ Industrial equipment
- ◇ Entertainment units

## 2 Pins Assignment and Description

### 2.1 Pin Assignment

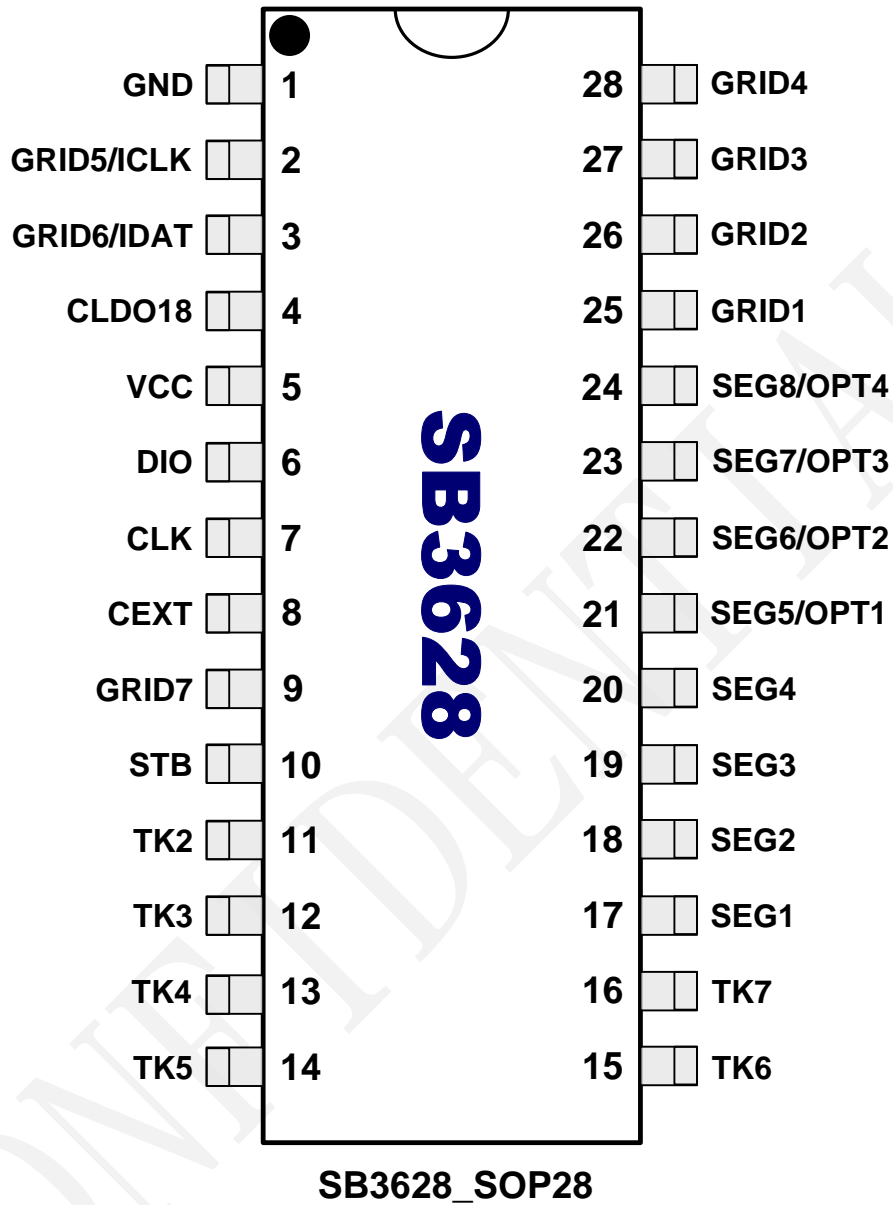

### 2.2 Pin Description

Pin No.	Pin Name	Type		Description
		Default	Reset	
1	GND	P	P	Ground
2	GRID5 ICLK	I/OD	I-PU	LED, GRID5 output Clock (ICLK), for X-ISP tool connection
3	GRID6 IDAT	I/OD	I-PU	LED, GRID6 output Data pin, for X-ISP tool connection
4	CLDO18	P	P	Internal LDO 1.8V power source, external 4.7uF earth capacitor
5	VCC	P	P	System power, input voltage 5V±10%
6	DIO	I/OD	Hi-Z	Serial pin, Data in/out
7	CLK	I	Hi-Z	Clock pin
8	CEXT	A	A	Reference capacitance input pin for touch keys, which needs to be externally connected to 3.9nF earth capacitor ( <b>this capacitor shall be made of 10% high accuracy NPO or X7R materials</b> )
9	GRID7	OD	Hi-Z	LED, GRID7 output
10	STB	I	Hi-Z	Chip select
11	TK2	A	Hi-Z	Capacitive touch key channel 2
12	TK3	A	Hi-Z	Capacitive touch key channel 3
13	TK4	A	Hi-Z	Capacitive touch key channel 4
14	TK5	A	Hi-Z	Capacitive touch key channel 5
15	TK6	A	Hi-Z	Capacitive touch key channel 6
16	TK7	A	Hi-Z	Capacitive touch key channel 7
17	SEG1	OP	Hi-Z	LED SEG1 output
18	SEG2	OP	Hi-Z	LED SEG2 output
19	SEG3	OP	Hi-Z	LED SEG3 output
20	SEG4	OP	Hi-Z	LED SEG4 output
21	SEG5 OPT1	I/OP	Hi-Z	LED SEG5 output Sensitivity adjustment OPT1
22	SEG6 OPT2	I/OP	Hi-Z	LED SEG6 output Sensitivity adjustment OPT2
23	SEG7 OPT3	I/OP	Hi-Z	LED SEG7 output Sensitivity adjustment OPT3
24	SEG8 OPT4	I/OP	Hi-Z	LED SEG8 output Cover type selection OPT4
25	GRID1	OD	Hi-Z	LED GRID1 output
26	GRID2	OD	Hi-Z	LED GRID2 output
27	GRID3	OD	Hi-Z	LED GRID3 output
28	GRID4	OD	Hi-Z	LED GRID4 output

**P:** Power ; **I:** Input; **OD:** Open Drain output; **I-PU:** Pull-up resistor (Rph) input;

**Hi-Z:** High impedance; **OP:** Push-pull output; **A:** Analog

### 3. Application Circuit

#### 3.1 Typical Application

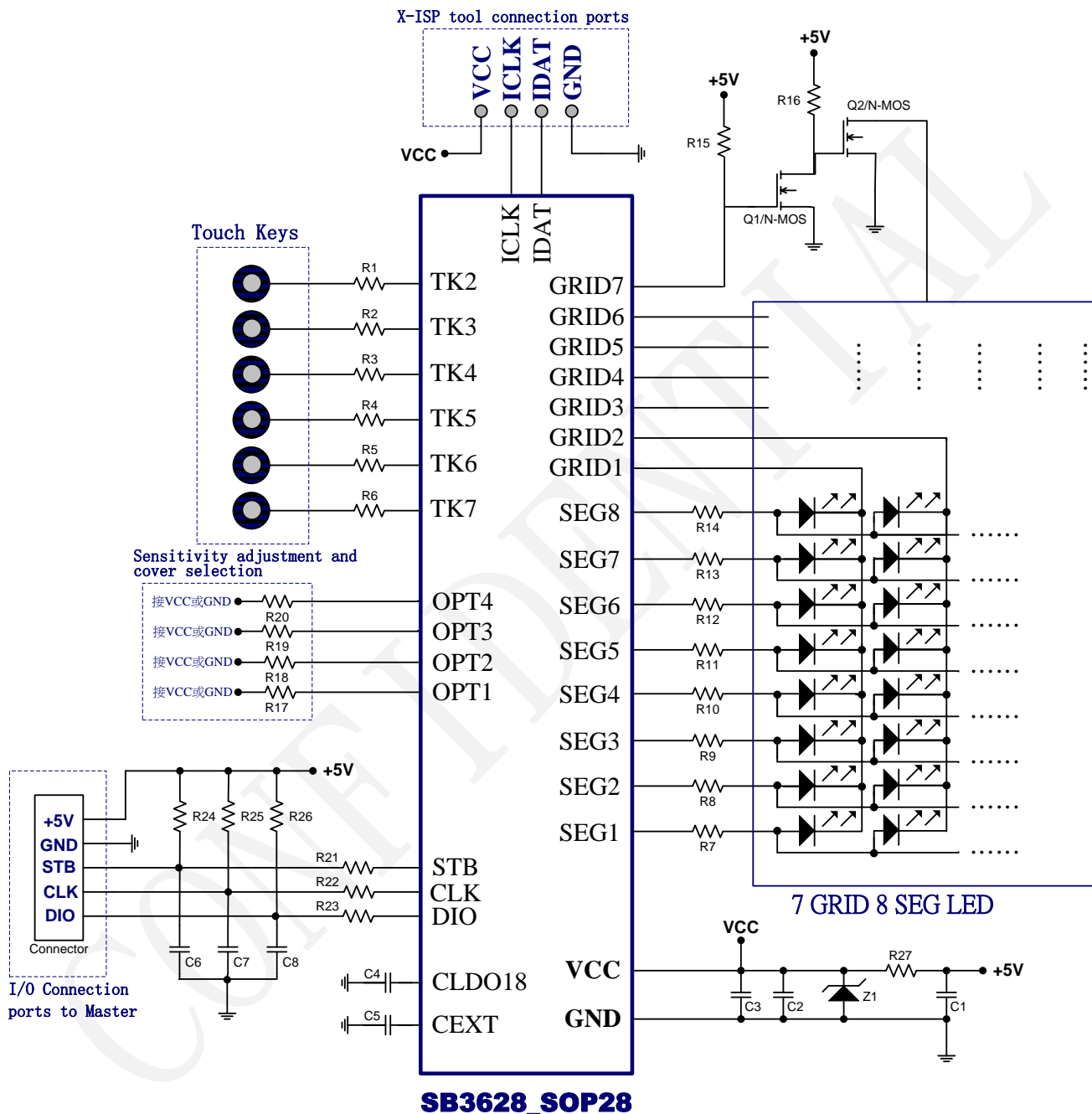

**Note:** ICLK and IDAT are communication interface used to connected with ene X-ISP debugging tools. User is able to obtain real-time SNR of TK2~ TK7 and monitor the stability of application item. If you need this tool, please contact ENE.

### 3.2 Circuit Elements Parameters

Component	Range	Suggested Value	Description
R1~R6	3.3K~10KΩ	10KΩ	TK2~TK7 TK protective resistor. The larger the resistance is, the higher the anti-interference capability will be (however, sensitivity will be reduced comparatively). User can select this resistor based on actual needs.
R7~R14	47~330Ω	200Ω	SEG driving current-limiting resistance. User can select this value based on actual luminance requirements.
R15	1KΩ	1KΩ	Q1 pull-up resistor
R16	4.7KΩ	4.7KΩ	Q2 pull-up resistor
R17~R20	200KΩ	200KΩ	OPT1~OPT4
R21~R23	0~1KΩ	100Ω	Serial port communication pin current-limiting protective resistor. User can select the resistance based on actual communicational speed.
R24~R26	4.7K~15KΩ	10KΩ	Serial port communication pin pull-up resistor.
R27	0~10Ω	10Ω	Chip input current-limiting protective resistor
C1	100~220μF	220μF	Input power regulator electrolytic capacitor
C2	22~47μF	47μF	Chip power regulator electrolytic capacitor
C3	104pF	104pF	Chip filter capacitor (chip capacitor available)
C4	4.7μF	4.7μF	Chip internal 1.8V regulator capacitor (chip capacitor available)
C5	3.9nF	3.9nF	Reference capacitor input pin ( <b>it shall be chip capacitor made of 10% high-accuracy NPO or X7R.</b> )
C6~C8	100~470pF	470pF	Input power regulator electrolytic capacitor
Z1	6.3V 0.5W~1W	Floating	Immunity enhance use
Q1/Q2	N-MOS	2N7002	GRID7 to N-MOS (note1)

Note 1: 2 N-MOS are required to drive GRID 7 as it doesn't have big current driving power. However, if user is using high brightness LED or require little LEDs, user may refer to the connection method in red square below for cost consideration.

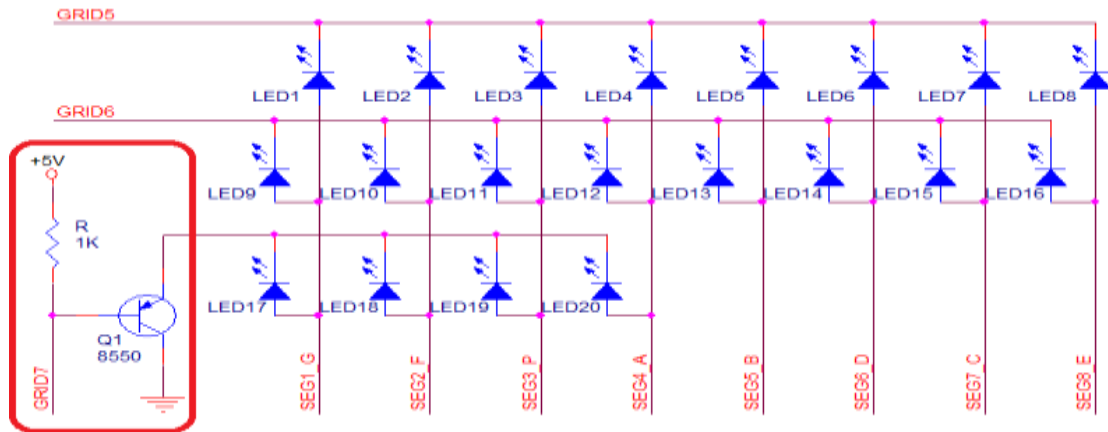

### 3.3 Application Example

Circuit example for 3mm acrylic cover, 6-CH TK, 7 GRID x 8 SEG LED:

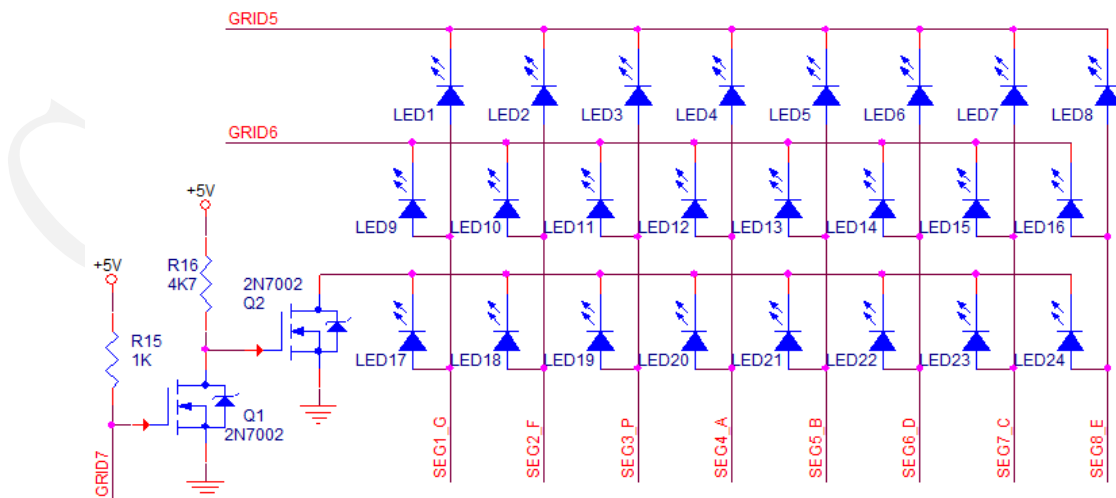
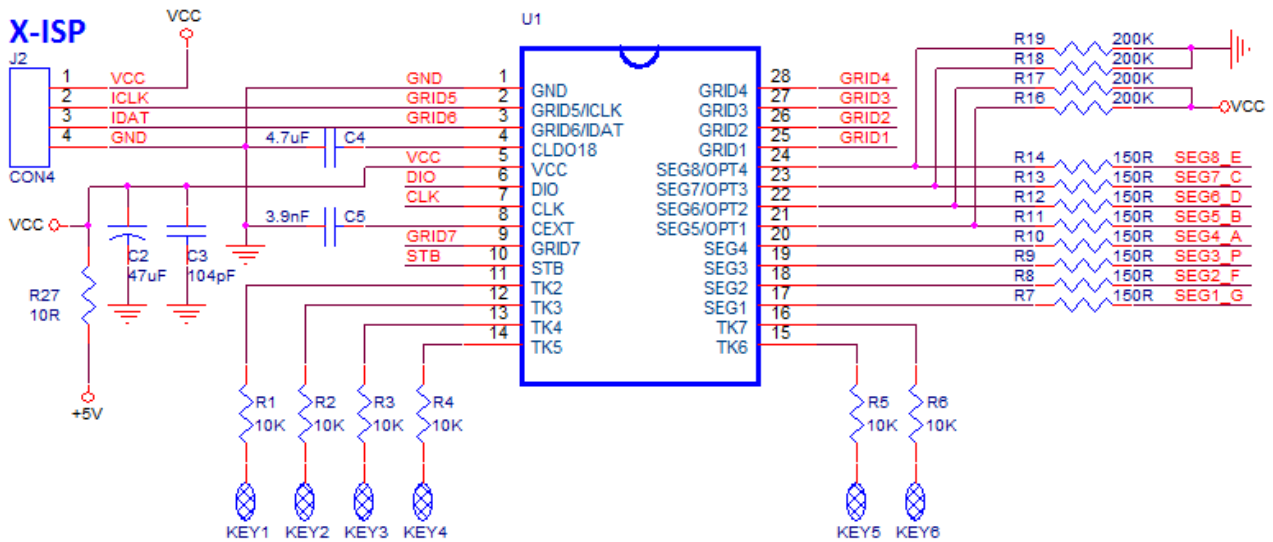

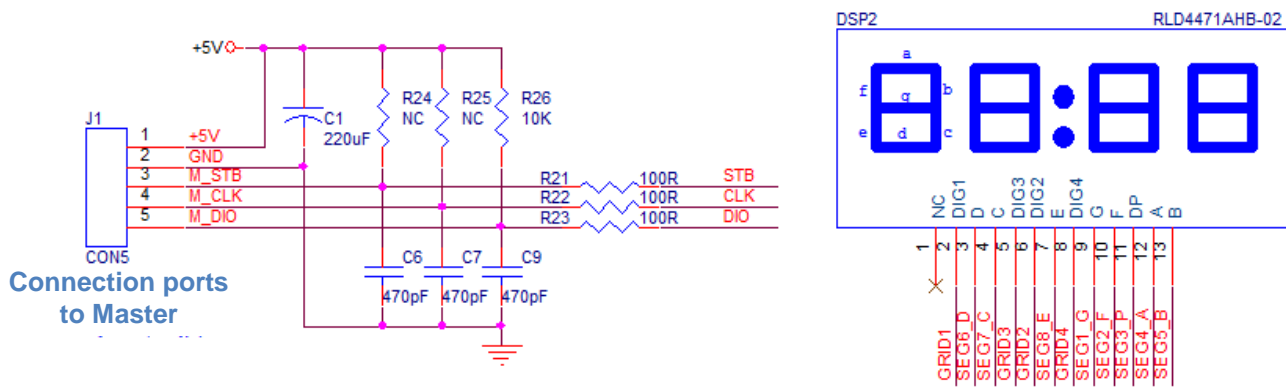

**▲Note:** J2 is used to connect with **X-ISP** debugging tools and doesn't belong to this project functions. However, it shall reserve soldering pad for future debugging.

CONFIDENTIAL

### 4. Cover Selection and Sensitivity Adjustment

#### 4.1 Cover Type Selection (OTP4)

OPT4 (external R20)	Cover Type
0	Acrylic
1	Glass

0: R20 is connected to GND;

1: R20 is connected to VCC.

#### 4.2 Sensitivity Adjustment (OPT3/OPT2/OPT1)

Sensitivity Level	OPT3 (external R19)	OPT2 (external R18)	OPT1 (external R17)	Cover Thickness (Unit: mm)	
				Acrylic	Glass
Level1	0	0	0	1.5	3.0
Level2	0	0	1	2.0	4.0
Level3	0	1	0	2.5	5.0
Level4	0	1	1	3.0	6.0
Level5	1	0	0	3.5	7.0
Level6	1	0	1	4.0	8.0
Level7	1	1	0	4.5	10.0
Level8	1	1	1	5.0	12.0

0 is connected to GND.

1 is connected to VCC.

**▲Note:** R17~R20 must connecte to GND or VCC.

#### 4.3 Standards of Sensitivity Test by Copper Stick

**SB3628** provides two choices of cover selection: Acrylic and Glass. Each comes with 8 different cover thickness. To test the sensitivity, prepare two different sizes of copper stick, 10cm length-10mm diameter and 10cm length-6mm diameter. Connect copper stick to SB3628 GND, hold the copper stick and touch the TK vertically with circuit. Test results as following:

**10mm-diameter copper stick:** When copper stick touches the TK, TK is able to be initiated;

**6mm-diameter copper stick:** When copper stick touches the TK, TK is unable to be initiated

Note: **SB3628** SNR is able to reach 10 and above. The respond rate of TK is 3/sec.

### 5. Transmission Format for Data Display Command

Host or MCU write SB3628 display data is transmitted automatically add mode to do the write address, display start address each set are from 00h start address command has been sent "STB" do not need to set high, as long as it followed then send display data to the data transfer up to 14 bytes (BYTE), data transfer to be completed and then "STB" is set high.

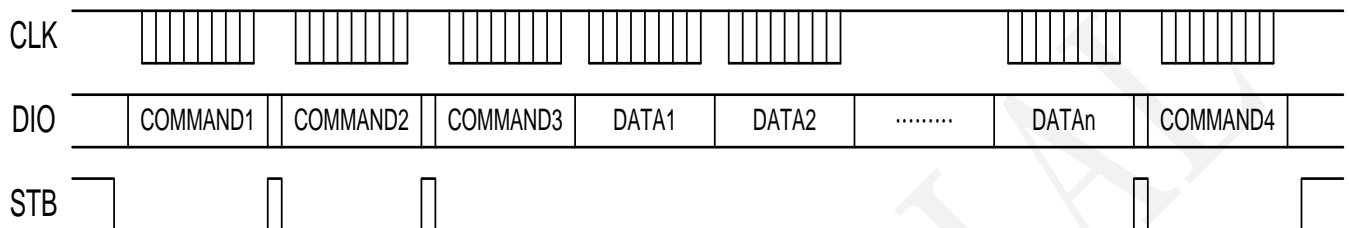

- COMMAND1: Display Mode configuration command (Default 0x02)
- COMMAND2: Data configuration command (Default 0x40)
- COMMAND3: Display Initial Address configuration command (Default 0xC0)
- DATA1~DATAn: Display Data Transmission (Max. 14 bytes)
- COMMAND4: Display Control configuration command

#### 5.1 Command Configuration

After falling in the first byte of each STB input from the DIO as a command, which take the highest Bit7 and Bit6 as bits are used to distinguish what kind of instruction command.

Command	B7	B6
Display Mode Configuration	0	0
Data Configuration	0	1
Display Control Configuration	1	0
Address Configuration	1	1

When the command or data transmission STB is set high, the serial communication is initialized, and the instructions being transmitted or the data is invalid (instruction or data prior to transmission remains valid).

#### 5.2 Corresponding Table for Display Mode Configuration

**SB3628** default configuration is 0x03 (represent 7 GRID 8 SEG display mode).

MSB				LSB				Display Mode
B7	B6	B5	B4	B3	B2	B1	B0	
0	0	"0" for irrelevant item			1	1	1	7 GRIDx 8 SEG

### 5.3 Corresponding Table for Data Configuration

MSB				LSB				Funciton	Description
B7	B6	B5	B4	B3	B2	B1	B0		
0	1	"0" for irrelevant item		0	0	0	0	Data Read/Write mode configuration	Write display data
0	1			0	0	1	0		Read TK staus
0	1			0	0			Address mode configuration	Automatic address addition

**▲Note:** This command is only for configuring Data Read/Write. Do not write 01 or 11 in B1 and B0.

### 5.4 Corresponding Table for Display Control Configuration

MSB				LSB				Funciton	Description
B7	B6	B5	B4	B3	B2	B1	B0		
1	0	"0" for irrelevant item			0	0	0	Configuration for Brightness	Pulse width configuration 1/15
1	0				0	0	1		Pulse width configuration 3/15
1	0				0	1	0		Pulse width configuration 5/15
1	0				0	1	1		Pulse width configuration 7/15
1	0				1	0	0		Pulse width configuration 9/15
1	0				1	0	1		Pulse width configuration 11/15
1	0				1	1	0		Pulse width configuration 13/15
1	0				1	1	1		Pulse width configuration 15/15
1	0				0				
1	0		1				Display On		

### 5.5 Corresponding Table for Address Configuration and Command Format

MSB				LSB				Address	
B7	B6	B5	B4	B3	B2	B1	B0		
1	1	"0" for irrelevant item		0	0	0	0	00H	
1	1			0	0	0	1	01H	
1	1			0	0	1	0	02H	
1	1			0	0	1	1	03H	
1	1			0	1	0	0	04H	
1	1			0	1	0	1	05H	
1	1			0	1	1	0	06H	
1	1			0	1	1	1	07H	
1	1			1	0	0	0	08H	
1	1			1	0	0	1	09H	
1	1			1	0	1	0	0AH	
1	1			1	0	1	1	0BH	
1	1			1	1	0	0	0CH	
1	1			1	1	1	0	1	0DH

### 5.6 Corresponding Table of Display Data and Address

SEG1	SEG2	SEG3	SEG4	SEG5	SEG6	SEG7	SEG8	X	X	X	X	X	X	X	X	
B0	B1	B2	B3	B4	B5	B6	B7	B0	B1	B2	B3	B4	B5	B6	B7	
00H								01H								GRID1
02H								03H								GRID2
04H								05H								GRID3
06H								07H								GRID4
08H								09H								GRID5
0AH								0BH								GRID6
0CH								0DH								GRID7

▲ **Note:** Address for effective data are: 0x00、0x02、0x04、0x06、0x08、0x0A、0x0C. Data from all other addresses are void.

CONFIDENTIAL

## 6. Read Format for TK Status Data

When Master issues 0x42 command (COMMAND1), it will then receive a 2-bytes data from SB3628 (DATA1~DATA2). This operation is for accessing current TK status of SB3628.

### 6.1 Time sequence of Reading TK status



### 6.2 Touch Key Status Data

DATA1 & DATA2 information:

**DATA1: TK2~TK7 Touch Key Status**

	B7	B6	B5	B4	B3	B2	B1	B0
TK No.	TK7	TK6	TK5	TK4	TK3	TK2	--	--

B7: TK7 status (0: not initiated, 1: initiated)

B6: TK6 status (0: not initiated, 1: initiated)

B5: TK5 status (0: not initiated, 1: initiated)

B4: TK4 status (0: not initiated, 1: initiated)

B3: TK3 status (0: not initiated, 1: initiated)

B2: TK2 status (0: not initiated, 1: initiated)

B0~B1: Void (Default: 0)

**DATA2:** DATA1 invert ( for verification purposes)

### 6.3 Related Control Registers

When Master issues 0x42 command it will then receive a 2-bytes data from SB3628. If DATA1=0x88 and DATA2=0x77, it means TK3 and TK7 are initiated, and TK2/TK4/TK5/TK6 are not.

## 7. Transmission Format of Serial Data

Read and receiving a Bit in clock rising edge execution.

### 7.1 Recieve Mode (Command/Data input)

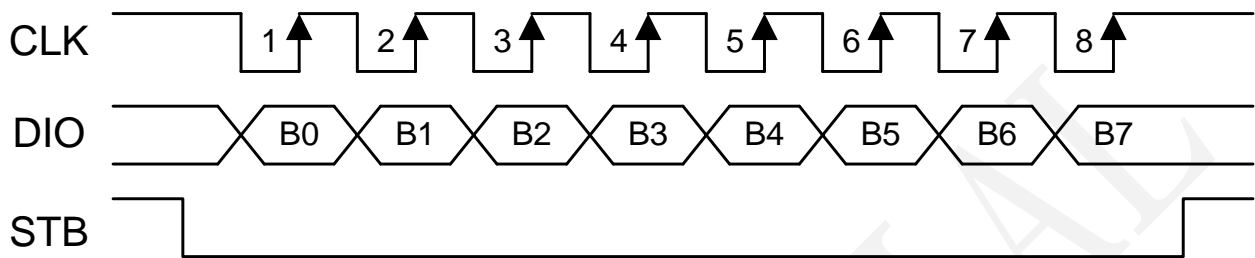

### 7.2 Read Mode (Data Read)

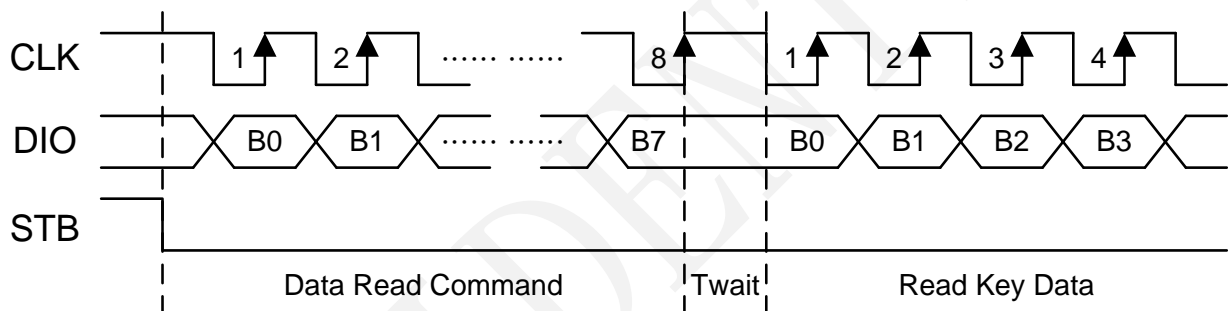

**▲Note:** In the read mode, the PC next After the first eight of the rising edge of CLK key command when you want to read keys. The first falling edge of CLK data begins to be delayed a Twait latency (Twait = 5μs)

## 8. Electrical Characteristics

### 8.1 Absolute Rating

Parameter	Symbol	Min	Typ	Max	Unit
DC Power Voltage	VCC	-0.3	--	6.0	V
Power Ground	GND	-0.3	0	0.3	V
Input/output voltage	Vin	GND-0.3	--	VCC+0.3	V
Operating Temperature	Ta	-40	--	85	°C
Storage Temperature	Tstg	-55	--	125	°C
ESD	Human Body Mode	--	--	8K	V
EFT	-- (*)	--	--	4K	V
CS	-- (**)	--	--	10	V

(\*) : EFT standard IEC61000-4-4 & GB17626.4 (5KHz/300mS)

(\*\*): CS standard IEC61000-4-6 & GB17626.6 (3Sec/0.15MHz~230MHz)

### 8.2 Normal Operating Range

Parameter	Symbol	Min	Typ	Max	Unit
Working Environment Temperature	T <sub>A</sub>	-40	25	85	°C
DC Power Voltage	VCC	4.5	5.0	5.5	V
Input High Voltage	V <sub>IH1</sub>	0.7VCC	--	VCC	V
Input Low Voltage	V <sub>IH2</sub>	0	--	0.3VCC	V

### 8.3 AC Characteristics ( Ta= -40~85 °C )

Parameter	Symbol	Condition	Min	Typ	Max	Unit
Oscillator frequency	F <sub>sys</sub>	VCC= 4.5V~5.5V	27.2	28.0	28.8	MHz
Oscillator startup time	T <sub>sys</sub>	VCC= 5V, F <sub>sys</sub> =28MHz	--	--	1.5	μS

### 8.4 DC Characteristics ( Ta= 25 °C , VCC=5V)

Parameter	Symbol	Condition	Min	Typ	Max	Unit
Operating Voltage	VCC	--	2.7	5.0	5.5	V
Operating Current	Iop	Fsys= 28MHz	--	4.0	6.0	mA
Port Pull-up Resistor	Rph	--	1.8	3.0	4.0	KΩ
Input High Voltage	Vih2	--	3.5	5.0	5.3	V
Input Low Voltage	Vil2	--	-0.3	0	2.1	V
Sink Current (STB/CLK/DIO/GRID7)	Iol3	Vol= 0.7V	11.2	14	--	mA
		Vol= 0.4V	6.4	8	--	
Source Current (STB/CLK/DIO/GRID7)	Ioh3	Voh= 4.5V	4	-5	--	mA
Sink Current (SEG1~SEG8)	Iol4	Vol= 0.7V	32	40	--	mA
		Vol= 0.4V	20	25	--	
Source Current (SEG1~SEG8)	Ioh4	Voh= 4.5V	15.2	-19	--	mA
Sink Current (GRID1~GRID6)	Iol5	Vol= 0.4V	116.8	146	--	mA
Source Current (GRID1~GRID6)	Ioh5	Voh= 3.0V	21.7	-27	--	mA

### 8.5 Power-on Reset Characteristics ( Ta= 25 °C , VCC=5V)

Parameter	Symbol	Condition	Min	Typ	Max	Unit
Reset Voltage	Vpors	--	1.9	2.1	2.3	V
Power-on Low Level Time after Power-off	Tpor_min	Fsys= 28MHz	1.0	--	--	mS
Conversion Time for Reset to Normal Operating Mode	Tpor_rst	Fsys= 28MHz	250	--	--	mS

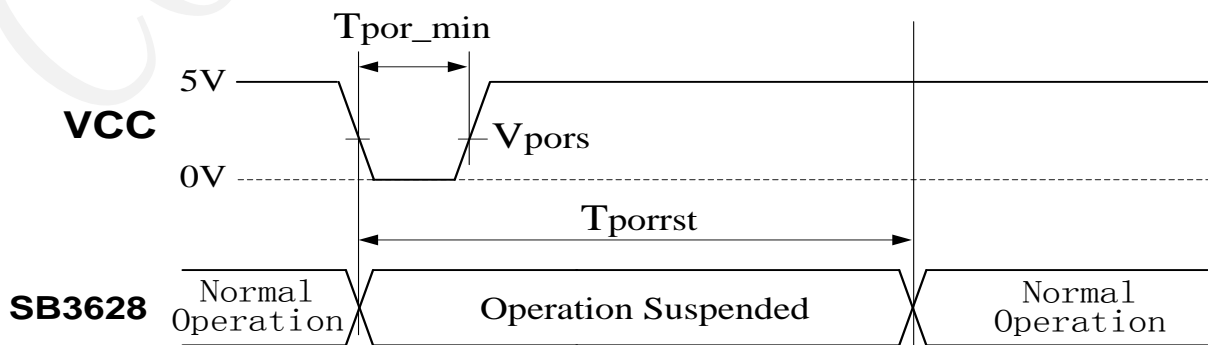

### 8.6 Switch and Time Sequence Characteristics ( Ta= -40~85 °C )

Parameter	Symbol	Condition	Min	Typ	Max	Unit
Transmission delay time	tPLZ	CLK → DOUT	--	--	5	μS
	tPZL	RL=10KΩ, CL=15pF	--	--	5	
Rising Time	tTZH1	CL=100pF SEG1~SEG8	--	--	1	μS
	tTZH2	CL=100pF GRID1~GRID7	--	--	1	
Falling Time	tTHZ	CL=100pF All SEG & GRID	--	--	1	μS
Serial port clock frequency	Fclk	Duty cycle 50%	--	--	70	KHz
Clock pulse width	PWCLK	--	7	--	--	μS
STB pulse width	PWSTB	--	7	--	--	μS
Data setup time	tSETUP	--	3	--	--	μS
Hold time	tHOLD	--	10	--	--	μS
CLK→STB time	tCLKSTB	CLK↑ → STB↑	13	--	--	μS
Waiting time	tWAIT	CLK↑ → CLK↓	6	--	--	μS

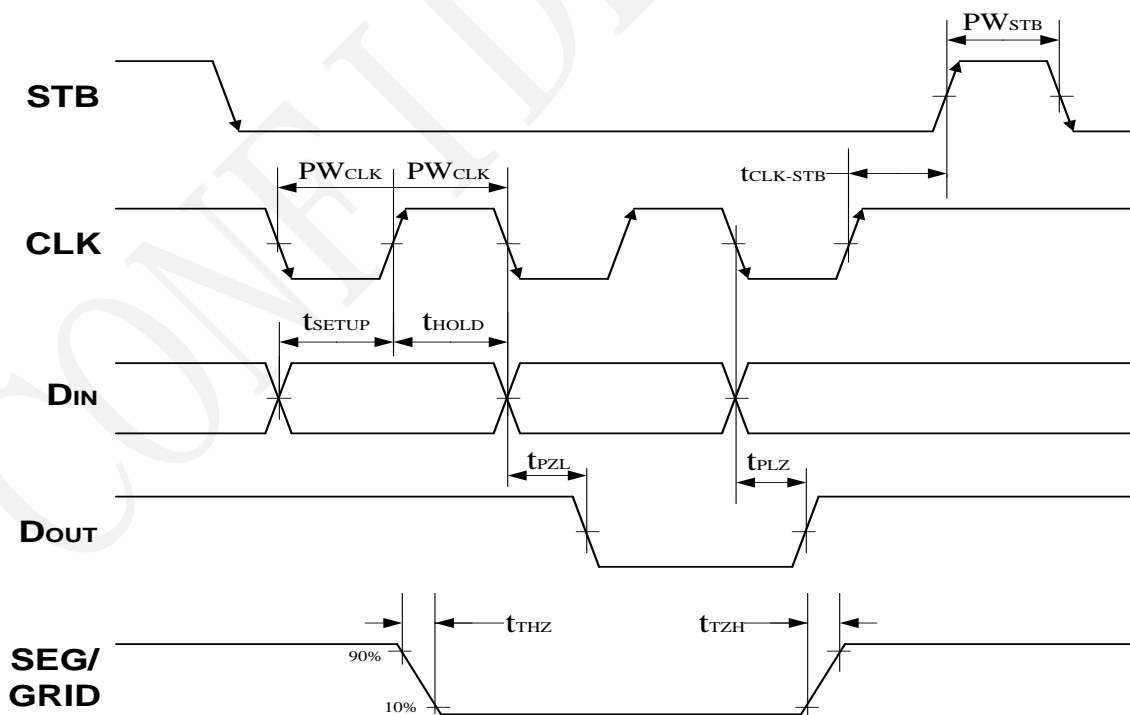

## 9. Packaging Information (28-SOP 300mil)

### 9.1 Dimensions

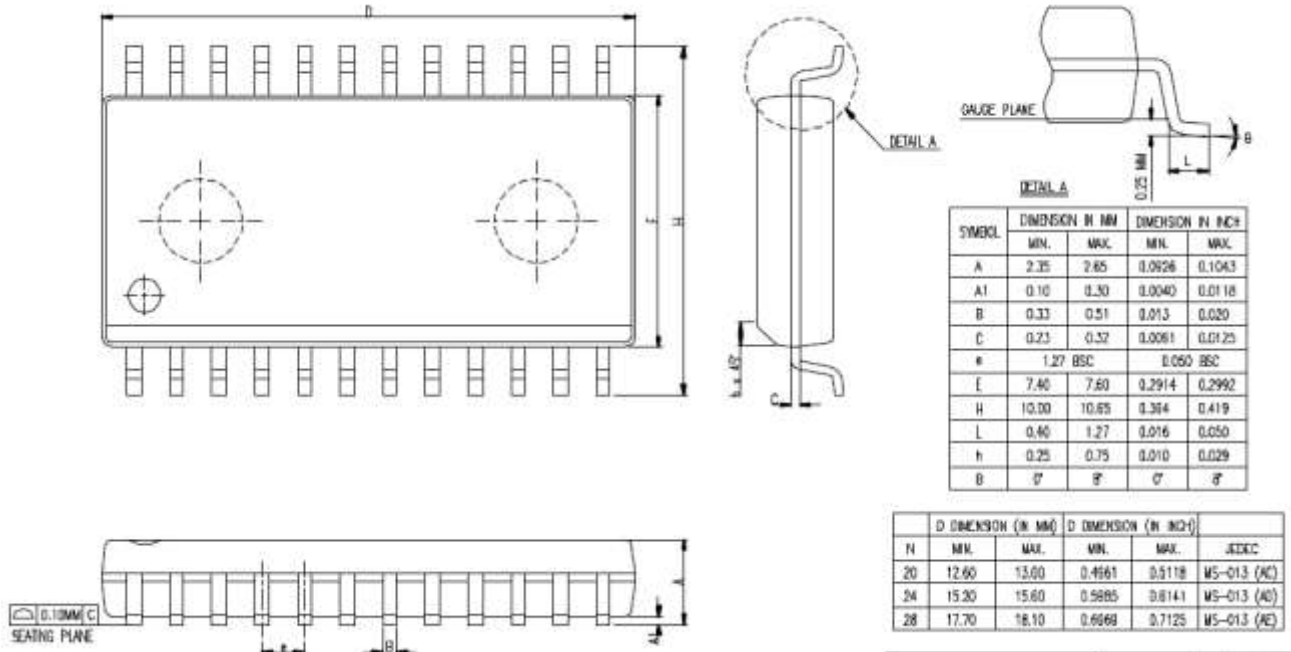

### 9.2 Manual Soldering Temperature Limitations

Part Number	Typical Soldering Temperature and Duration
SB3628	350°C, 3~5sec

### 9.3 Part Number Descriptions

Part Number	Package Size	Lead Free Process	Status
SB3628	28-SOP 300mil	Lead Free	Mass Production

### 9.4 Processing Technique Data

No.	Process Requirements	Note
1	Materials and surface coating of elements and tubes	Tin
2	Base materials and CTE of elements	Molding compound C1: 8 ppm/°C; C2 : 32ppm/°C Conductive adhesive C1: 80 ppm/°C; C2 : 200 ppm/°C
3	Elements coplanarity QFP	< 0.076mm
4	Operating temperature	Normally room temperature
5	Soldering temperature (preheating, baking soldering, including maximum soldering temperature and supportable repair times	260°C (+0, -5) / 3time
6	Solder , soldering process curve description is as follows.	Please follow Jedec standard: J-STD-020D
7	Heat durability	< 260°C
8	Dimensions and weight	SOP28 L*W*H =17.9*7.5*2.5mm; 0.78g
9	Humidity sensitivity level	MSL3
10	Electrostatic sensitivity level	HBM: ≤ 8000 V
11	Device package and storage life	1 year, or 168 hours after unpacking sealed package. Environmental temperature < 30°C , humidity 60% RH

## Reflow Soldering Temperature Curve

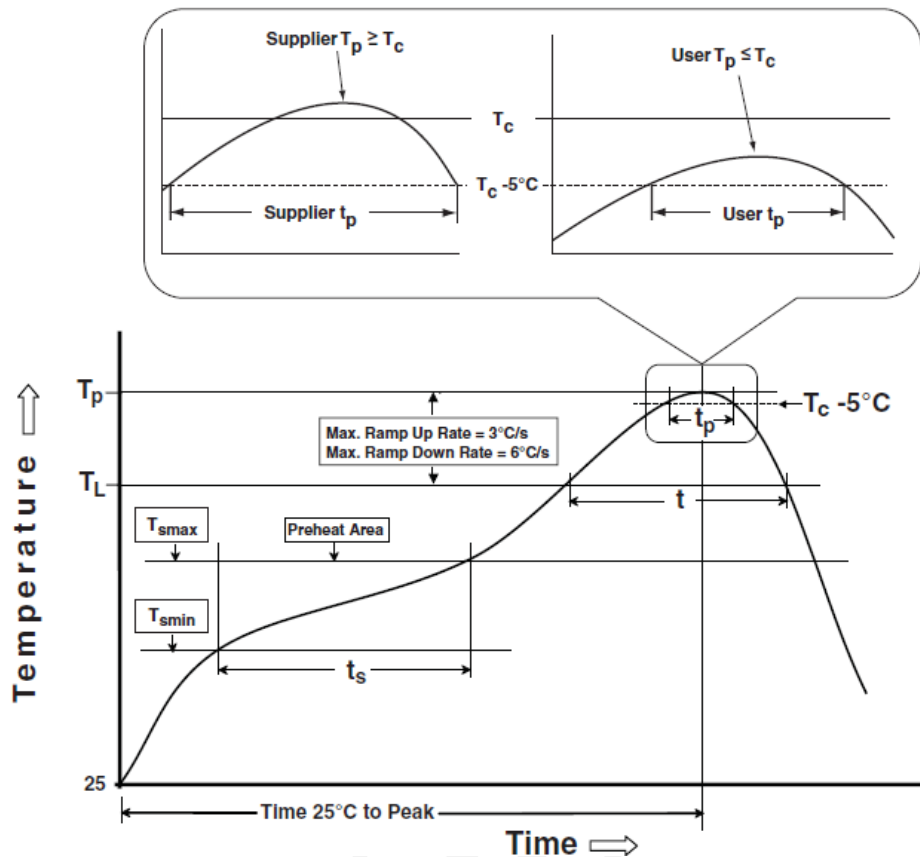

## Reflow Soldering Temperature Distribution

Temperature Distribution Characteristics	Lead-free solder
Average ramp up rate ( $T_1 - T_p$ )	Maximum 3°C/S
Preheat/prewatering - Temperature Min ( $T_{S \min}$ ) - Temperature Max ( $T_{S \max}$ ) - Duration (from $T_{S \min}$ to $T_{S \max}$ )	150°C 200°C 60~120S
Hold time: - Temperature ( $T_L$ ) - Time ( $t_L$ )	217°C 60~150S
Time within peak/category temperature ( $t_P$ ) 5°C	Refer to Figure 1
Time within actual peak temperature ( $t_P$ ) 5°C	30S
Ramp up rate	Maximum 6°C/S
Time 25°C to peak	Maximum 8 minutes

**Figure 1: Lead-free Soldering Process--Packaging Reflow Soldering Temperature**

Package thickness	Volume mm3 < 350	Volume mm3 350-2000	Volume mm3 > 2000
<1.6mm	260+0°C	260+0°C	260+0°C
1.6mm-2.5mm	260+0°C	250+0°C	245+0°C
≥2.5mm	250+0°C	245+0°C	245+0°C

CONFIDENTIAL

## 10. Important Notice

### 10.1 Software

- ◇ The host or MCU for the first time after the STB SB3628 pulled low, then delayed **20 $\mu$ S** serial communication.
- ◇ The host or MCU query interval of not less than SB3628 **5mS**.

### 10.2 Power Supply

The quality of system power is a key factor to TK sensing technology. A good power system design improves TK performance dramatically. In some power noise tests **SB3628** provides HW and FW solutions to compensate system power variations during tests.

#### 10.2.1 Internal Power (Internal LDO)

##### CLDO18

There is an internal LDO to provide **SB3628** stable 1.8V for circuit operation. This power is not used for power source of other components. One **4.7 $\mu$ F** capacitor is required for internal 1.8V LDO, it's recommended to place capacitor close to CLDO1.8 input pin.

#### 10.2.2 System Power VCC

##### VCC

A pair of low ESR and ESI X7R ceramic surface-mount appliance (SMD) **0.1 $\mu$ F** capacitors in parallel an X7R or X5R ceramic surface-mount appliance (SMD or electrolytic capacitor) **10 $\mu$ F** capacitor should be placed as close to the VCC and GND pins of **SB3628**.

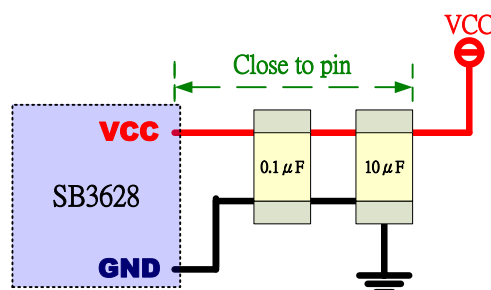

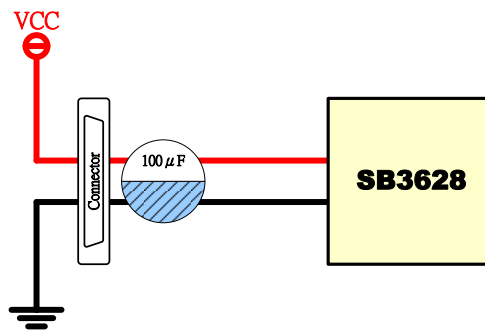

### 10.2.3 Power Range and Requirements

The VCC power range for SB3628 is **2.7V~5.5V**. That means SB3628 works normally with VCC power varies between **3.0V~3.6V** or **4.5V~5.5V**, instead of supplying VCC varies between **4.5V ~ 5.5V**.

Although TK18 is able to maintain instantaneous voltage variation and power supply noise at different frequencies, please note the voltage noise level must be less than **±100mV**. Impact of any instability or impulse noise applied to the VCC will seriously affect TK behavior.

If possible, have a good PSRR LDO for VCC, and position it as close as possible to SB3628.

## 10.3 PCB Design

In typical SB3628 applications, the capacitive sensor may be constituted by the PCB routing traces and different shapes of sensor pads. The following sections depict PCB design guidelines for using SB3628.

Please note that any noisy components, such as switches, transformers, oscillator, etc., must be placed as far away as possible from SB3628, sensor pad and sensor routing traces. Other metal base or digital signals may cause capacitive crosstalk to affect SB3628 performance.

### 10.3.1 Power and Ground Design

The quality of power and ground design is fundamental and key to capacitive touch key performance, please note and follow the design rules below:

#### Mesh Ground:

If shielding layer is not used, it's recommended to have mesh ground on top and bottom layers. The mesh ground improves not only TK sensitivity but also noise immunity.

To obtain good SNR and RF noise immunity, it's recommended to route the ground trace with 5mil trace width. The spacing between traces is 20mil, the hatch grid is 20mil, and the spacing between sensor pad and mesh ground is 20~40mil.

However, some of PCB manufacturing houses require the routing trace width to be more than 10mil to achieve better production yield, in this case, it's recommended to have ground trace width is 10 mil,

and the hatch grid is 40 mil accordingly.

The following pictures illustrate the sensor pads on top layer and the sensor traces on bottom layer.

### The sensor pad and mesh ground on top layer:

#### The sensor pad and mesh ground on top layer:



#### The sensor traces and mesh ground on bottom layer:



### 10.3.2 PCB Layout

Please follow general PCB layout rules, for instance, to route the traces with 45-degree instead of right angle to avoid EMI issues.

#### VCC/GND traces and through holes for power source:

VCC/GND traces are recommended to be **25~30mil** width to reduce equivalent resistance and inductance.

The decoupling capacitors are recommended to add to through holes of power source as illustrated below, the noise introduced by power source will be decoupled by the capacitors. The through holes of VCC/GND are recommended to be **30/18mil** to reduce equivalent inductance.

#### SB3628 VCC trace and through hole:

**▲Note:** The VCC traces between VCC and SB3628 should go through the decoupling capacitors instead of routing branches to capacitors. The decoupling capacitors should be placed as close to the TK18 VCC pin.

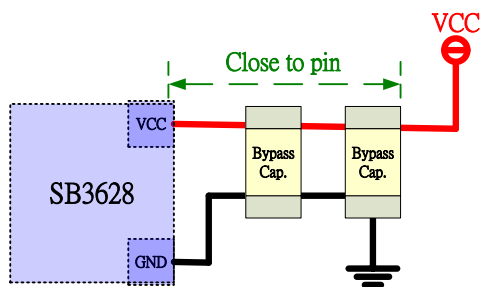

### The trace for internal LDO bypass capacitor:

It's recommended to have **10~20mil** trace width for internal LDO bypass capacitor routing to provide TK18 a stable power source.

### The ground return path of IC:

The ground return path of SB3628 should be connected to the ground of VCC decoupling capacitors, and route the ground trace as short as possible to the connector. Avoid redundant routing traces as well as becoming "Loop Antenna".

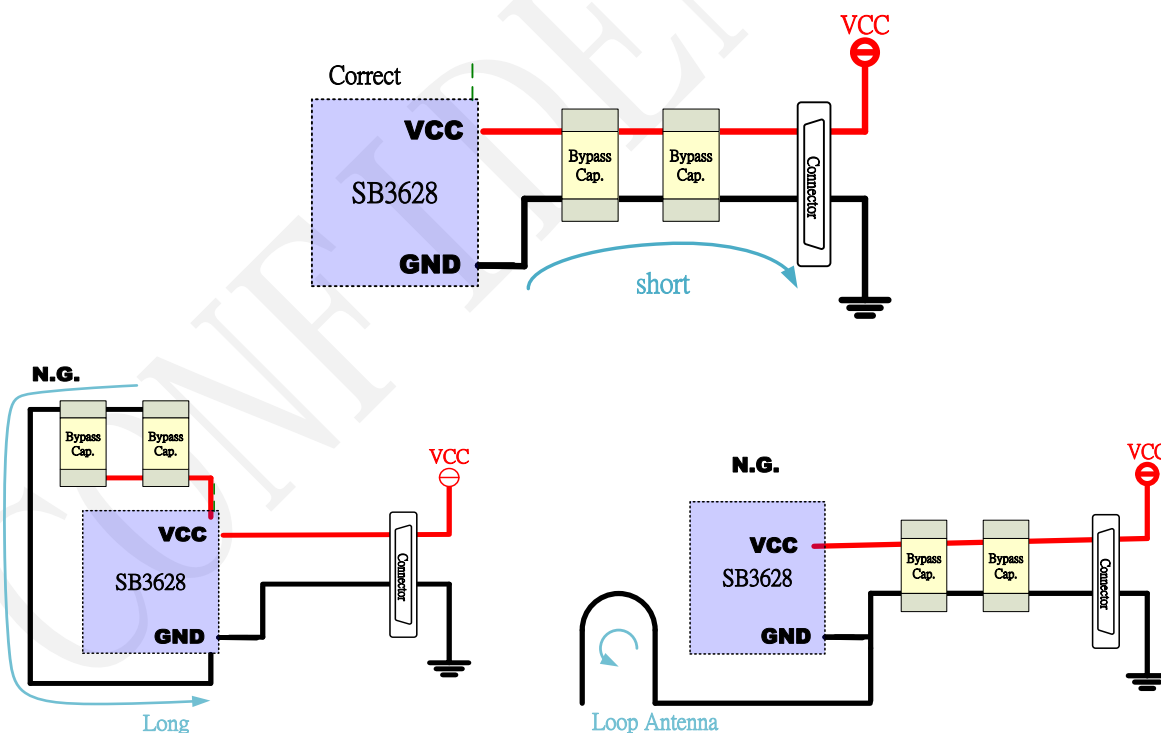

### Sensor Pad/Touch Key

For 2-layer PCB case, it's recommended to have **5~10mil** trace width to connect sensor pad/touch key with TK18. The distance between every two sensor traces is recommended to be twice of the sensor trace width (**10~20mil**) to avoid interference.

The longer sensor trace length introduces larger parasitic capacitor, so the sensor traces should be as short as possible, it's recommended to be within **150mm**.

Note: Do not route any signal trace to overlay sensor pad, that will cause severe crosstalk to fail TK function.

### Preferred vs. inappropriate sensor trace routing examples:

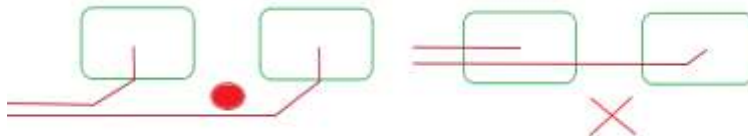

### LED signals and sensor traces

The LED control signals are prohibited to be routed in parallel with the sensor traces, please insert ground shielding lines between LED control signals and sensor traces, otherwise, the traces routing spacing should be at least 50mil.

**▲Note:** The inserted shielding lines should be connected to ground at both sides. Otherwise, it will form a uni-polar antenna that suffers EFT immunity.

### The ground shielding lines between LED control signals and sensor traces:

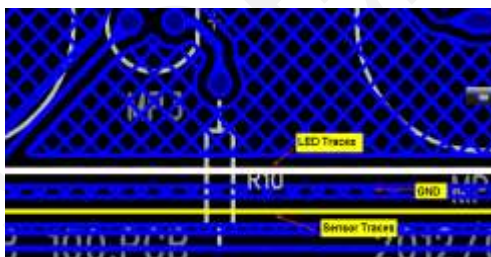

**▲Note:** If LED control signals crossover sensor traces, it is recommended to use another plane jumper to cross lines instead of using SMT components. By doing this, the vertical distance between LED control signals and sensor traces will maintain in PCB thickness (1.6mm) to guarantee EFT immunity.

### 10.3.3 CEXT

Cext is the external capacitor used for TK charge transfer operation, this is one of key factors to capacitive sensing technology, it's recommended to place this component close to SB3628 and ground, the trace width connected to ground is at least **10mil**.

The recommended Cext for SB3628 is 3.9nF (ceramic capacitor).

**▲Note:**The ground of Cext needs the shortest path back to the ground of VCC decoupling capacitor (0.1uF) and LDO18 capacitor (4.7uF), then connect to the Power/GND connector. The routing example is illustrated below.

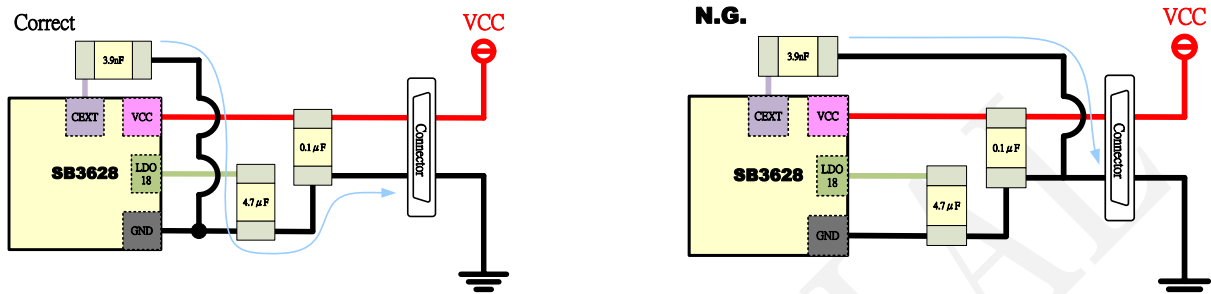

### 10.3.4 Sensor pad and through hole for TK

The sensor pad design is fundamental to TK performance. The following chapter depicts the design guideline for sensor pad shape, size, placement and trace routing.

#### The size and shape of sensor pads (TK)

The proposed shape of sensor pad is round or rectangular, please refer to the diagrams below.

The recommended size is:

- ◇ Solid Circle: recommended size 10mm(diameter) ~ 20mm(diameter)。
- ◇ Square: recommended size 11mm(length) x 11mm(width) ~ 16mm(length) x 16mm(width)。
- ◇ Rectangle: recommended size 12mm(length) x 10mm(width) ~ 20mm(length) x 15mm(width)。

#### Preferred shapes of sensor pad:

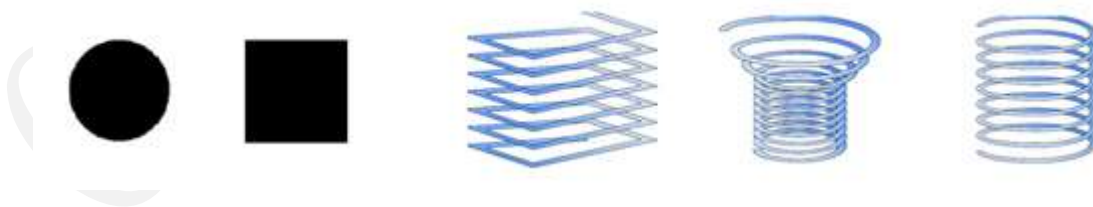

#### Undesired shapes of sensor pad:



### The sensor pad design example for round shape

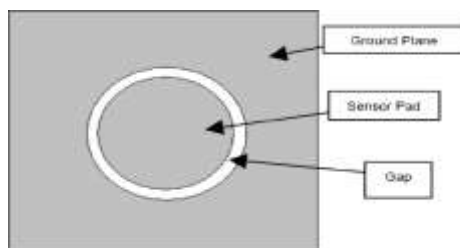

A typical round shape sensor pad is illustrated above. There is a round gap that isolates the sensor pad and the ground plane.

In the case of sensor pad with 15mm diameter or larger, the expansion of sensor pad size is ineffective to increase sensitivity. In contrast, larger sensor pad size will decrease the spacing between each other that may cause false trigger due to crosstalk.

In the case of sensor pad with 5mm diameter or less, the sensing capacitor will be too small to achieve adequate sensitivity.

### The spacing between sensor pad and ground plane

It's recommended to reserve 20mil (0.5mm) spacing between sensor pad and ground plane.

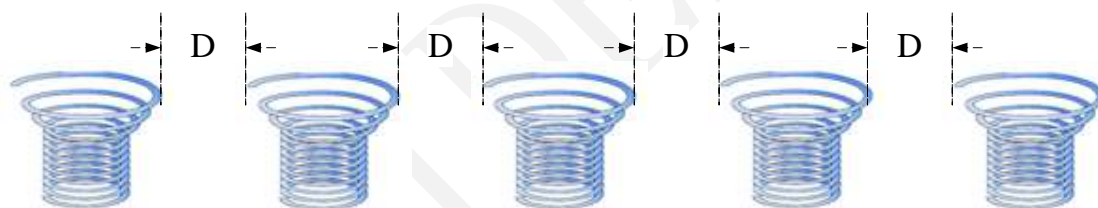

### Through hole

It's recommended to route the shortest trace length between TK18 and sensor pad without through hole, if the through hole is inevitable, the through hole number should be less than 2.

The through hole can be placed anywhere of sensor pad, please refer to the following diagrams. The through hole at the center of sensor pad has symmetry physical characteristics. However, the through hole at the edge of sensor pad has shorter routing trace that depends on system design flexibility.

### Through hole of sensor pad

