



SB32xx

Immunity Enhanced TK Controller Datasheet

Revision 1.0
July 2015

ENE RESERVES THE RIGHT TO AMEND THIS DOCUMENT WITHOUT NOTICE AT ANY TIME. ENE ASSUMES NO RESPONSIBILITY FOR ANY ERRORS APPEAR IN THE DOCUMENT, AND ENE DISCLAIMS ANY EXPRESS OR IMPLIED WARRANTY, RELATING TO SALE AND/OR USE OF ENE PRODUCTS INCLUDING LIABILITY OR WARRANTIES RELATING TO FITNESS FOR A PARTICULAR PURPOSE, OR INFRINGEMENT OF ANY PATENTS, COPYRIGHTS OR OTHER INTELLECTUAL PROPERTY RIGHTS.

Headquarters
4F-1, No.9, Prosperity Rd.,
Science-based Industrial Park,
Hsinchu City, Taiwan, R.O.C
TEL: 886-3-6662888
FAX: 886-3-6662999
<http://www.ene.com.tw>

Revision History

Revision	Description	Date
1.0	Initial Release	2015/07

Content

CONTENT	3
1. GENERAL DESCRIPTION.....	4
1.1 OVERVIEW	4
1.2 APPLICATIONS.....	4
1.3 FEATURES.....	4
2. SELECTION TABLE AND PIN ASSIGNMENT AND DESCRIPTION	2
2.1 SELECTION TABLE	2
2.2 PIN ASSIGNMENT.....	2
2.3 PIN DESCRIPTION	3
3 FUNCTIONAL DESCRIPTION.....	4
4. APPLICATION CIRCUIT	6
4.1 SB3206 APPLICATION CIRCUIT	6
4.3 SB3208 APPLICATION CIRCUIT	6
5. ELECTRONIC CHARACTERISTICS.....	7
5.1 ABSOLUTE RATING	7
5.2 NORMAL OPERATING RANGE.....	7
5.3 DC CHARACTERISTICS (TA=25°C)	7
6. PACKAGING INFORMATION.....	9
7. CONTACT DETAILS	11

1. General Description

1.1 Overview

The SB32xx series of 6 or 8 key immunity enhance TK controller are capable of detecting touch on electrode covered by dielectric material such as glass or plastic. Touch sensing technology is implemented in many fields such as appliances, control panels, or replacing of mechanical switches/buttons. Capacitive sensing technology is more robust and overall cost advantage.

Detail functionality is different by parts; please refer the following pages for each specification.

1.2 Applications

- Home Appliances
- Monitors & TVs
- PCs & PADs
- Smart Phones

1.3 Features

- Support typical 3.0V/5V operating voltage with 2.7V~5.5V swing.
- Support at max. 8 capacitive sensor buttons.
- Capacitive touch button controller.
- Standby and normal operating modes.
- Adaptive voltage drop function.
- Minimal number of external components.
- Output type: Level-hold.
- High reliability touch detections.
- High PSRR.

2. Selection table and pin assignment and Description

2.1 Selection table

Part NO	Touch Key	Parallel Outputs	Power Mode	Auto Calibration	Package
SB3206	6	V	Normal and Standby	V	NSOP16
SB3208	8	V	Normal and Standby	V	SOP20

2.2 Pin Assignment

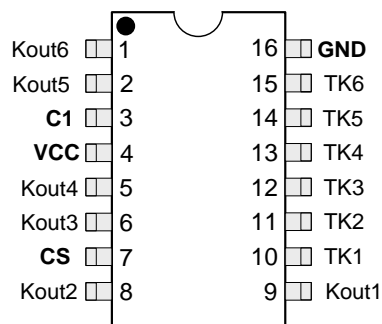

**SB3206
NSOP16**

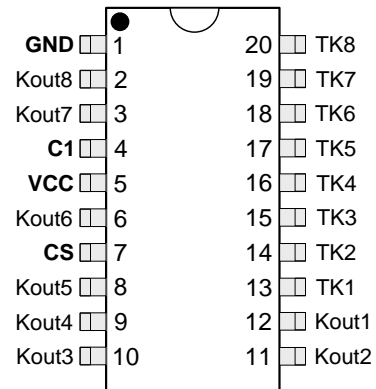

**SB3208
SOP20**

2.3 Pin Description

- SB3206

Pin Name	I/O	Description
TK1~TK6	Input	Touch key input pin, unused touch keys require floating.
Kout1~Kout6	CMOS output	Touch key output pin and active low.
VCC	---	Positive power supply
GND	---	Negative power supply, ground
C1	Input	External capacitor is 1uF
Cs	Input	Reference capacitor input pin with 3.9nF. (it shall be chip capacitor made of 10% high-accuracy NPO or X7R.)

- SB3208

Pin Name	I/O	Description
TK1~TK8	Input	Touch key input pin, unused touch keys require floating
Kout1~Kout8	CMOS output	Touch key output pin and active low.
VCC	---	Positive power supply
GND	---	Negative power supply, ground
C1	Input	External capacitor is 1uF
Cs	Input	Reference capacitor input pin with 3.9nF. (it shall be chip capacitor made of 10% high-accuracy NPO or X7R.)

3 Functional Description

Sensitivity Adjustment

The sensitivity of the switch is a very important consideration in most applications whose requirements will vary according to the user application. The user should therefore be aware of the factors which will affect the overall sensitivity of their touch key application. Factors to take into consideration include the electrode size and the capacitance of the connection lines from the electrode to the SB32xx device. Therefore the sensitivity will vary according to the actual PCB layout and design.

Adaptive Voltage Drop

The SB32xx devices of touch key devices include an adaptive voltage drop function which prevent touch key malfunction due to power supply voltage variations which may be caused by high current switching. With the adaptive voltage drop function, there is no need for an external LDO to deal with these voltage drop issues.

Touch key pad size

Larger touch key sizes will increase sensitivity and of course vice-versa, small electrode sizes will decrease sensitivity.

The proposed shape of sensor pad is round or rectangular, please refer to the diagrams below. The recommended size is 10mmx10mm (square), 8mmx12mm (rectangular), or 11mm diameter (round).

Touch key pad insulating panel thickness

A thinner panel will result in higher sensitivity and of course thicker panels will result in a lower sensitivity.

Touch key reference capacitor input (CS)

Cs is the external capacitor used for TK charge transfer operation, this is one of key factors to capacitive sensing technology, it's recommended to place this component close to SB32xx and ground, the trace width connected to ground is at least 10mil.

- The recommended Cs for SB32xx is 3.9nF (ceramic capacitor).
- Note: The ground of Cs needs the shortest path back to the ground of VCC decoupling capacitor (0.1uF) and C1 capacitor (1uF), then connect to the Power/GND connector. The routing example is illustrated below.

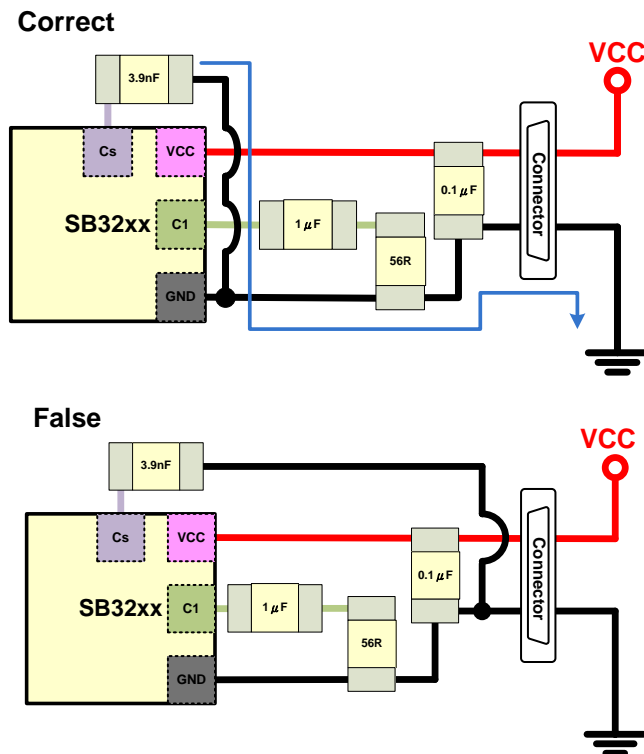

Touch key pad insulating panel material

The choice of the dielectric material for the panel will influence the sensitivity. Materials with higher dielectric constants will result in higher sensitivities and lower dielectric constants will result in lower sensitivities.

For materials which are in direct contact with the sense PAD, metallic or carbon containing conducting materials must not be used. It is recommended that a material with a dielectric constant, K of value between 1.5 and 4 is used. Examples would be glass, acrylic, plastic, PMMA etc.

4. Application Circuit

4.1 SB3206 Application Circuit

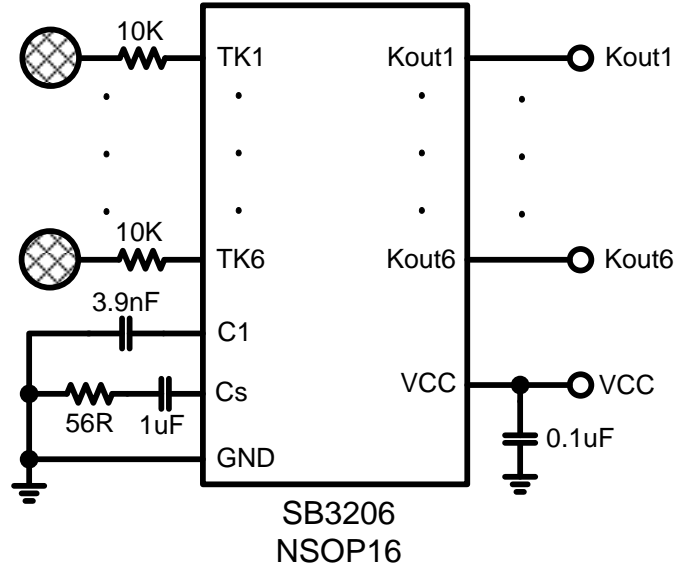

4.3 SB3208 Application Circuit

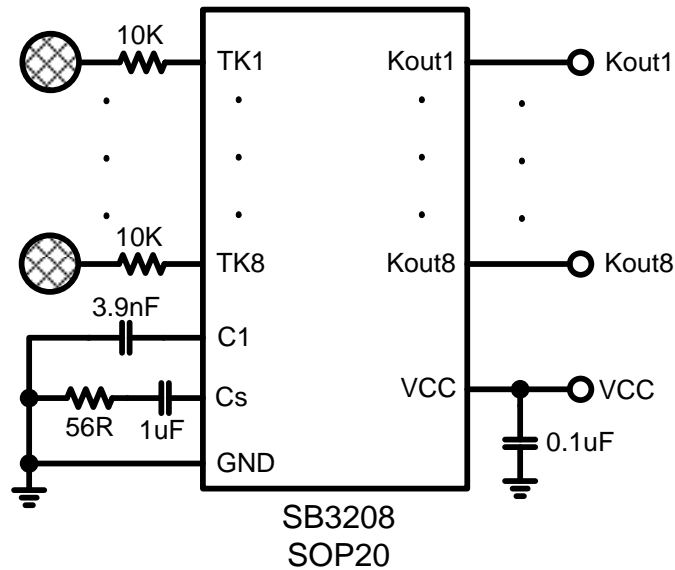

5. Electronic Characteristics

5.1 Absolute Rating

Symbol	Parameter	Min	Typ	Max	Unit
T _A	Operating Temperature	-40	--	85	°C
T _{STG}	Storage Temperature	-55	--	125	°C
VCC	DC Power Voltage	2.7	---	6.0	V
GND	Power Ground	-0.3	0	0.3	V
IDD	Max. IDD	---	---	100	mA
ESD	Human Body Mode	--	--	8K	V
EFT	Electrical Fast Transient	--	--	4K	V
KDE	Key Debounce	90	100	110	ms
TKPZ	Touch Key Pad Size	10	--	15	mm
IPT	Insulating Panel Thickness	1	--	5	mm

5.2 Normal Operating Range

Symbol	Parameter	Min	Typ	Max	Unit
T _A	Working Environment Temperature	-40	25	85	°C
VCC	DC Power Voltage	4.5	5.0	5.5	V
V _{IH1}	Input High Voltage	0.7VCC	--	VCC	V
V _{IH2}	Input Low Voltage	0	--	0.3VCC	V

5.3 DC Characteristics (TA=25°C)

Symbol	Parameter	Condition	Min	Typ	Max	Unit
VCC	Operating Voltage	--	2.7	--	5.5V	V
V _{POR}	Reset Voltage	--	1.9	2.1	2.3	V
I _{OP}	Operating Current	VCC = 5.0V	--	4.0	6.0	mA
		VCC = 3.3V	--	3.0	4.5	

(Continuance 1)

Symbol	Parameter	Condition	Min	Typ	Max	Unit
I_{OL}	Kout Sink Current	VCC = 5.0V, VOL = 0.7V	11.2	14	16.8	mA
		VCC = 3.3V VOL = 0.7V	8	10	12	
		VCC = 5.0V VOL = 0.4V	6.4	8	9.6	
		VCC = 3.3V VOL = 0.4V	4.8	6	7.2	
I_{OH}	Kout Source Current	VCC = 5.0V VOH = 4.5V	4	5	6	mA
		VCC = 3.3V VOH = 2.8V	3.2	4	4.8	

6. Packaging Information

SOP20 (300mil)

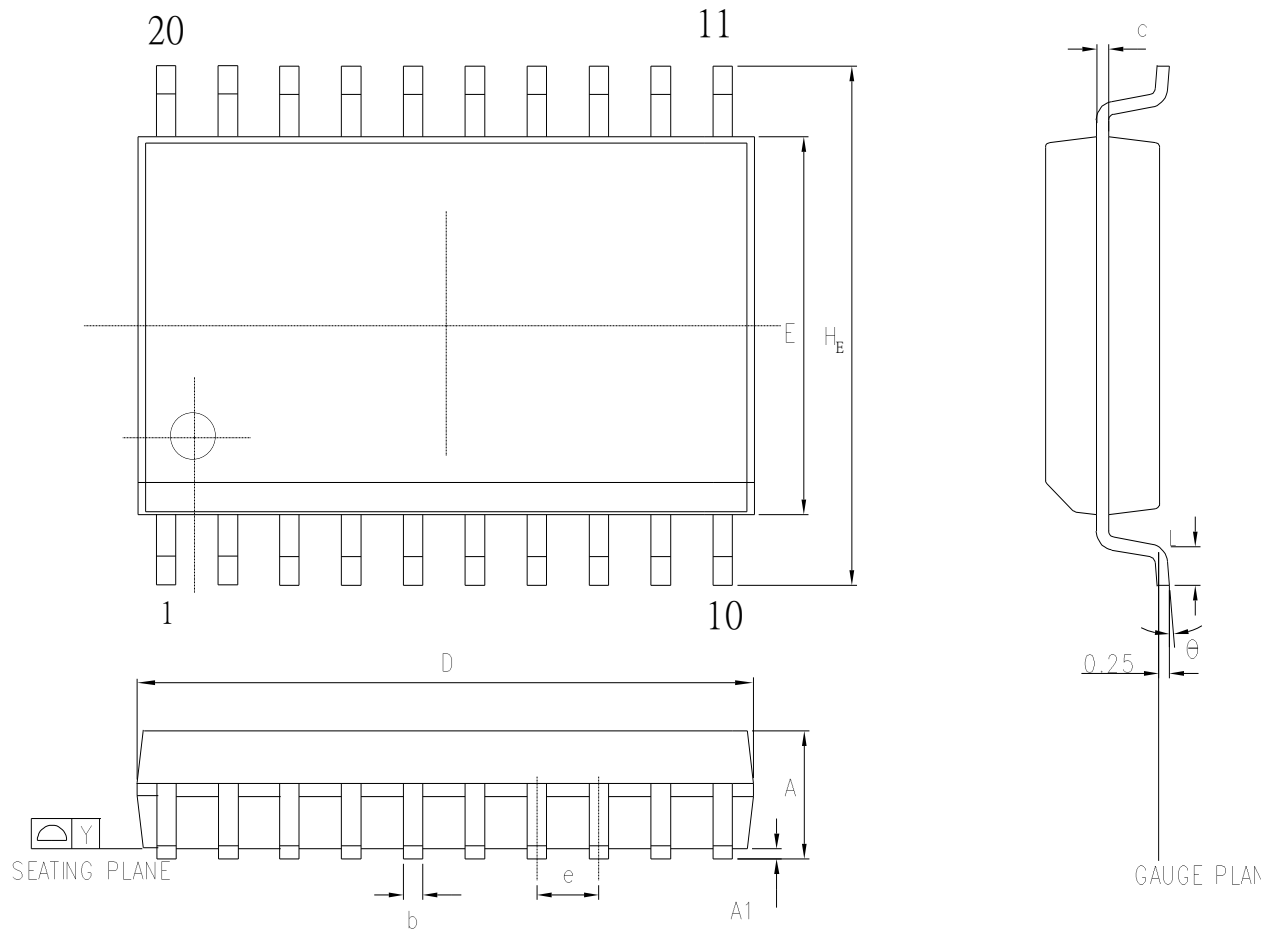

Control demensions are in milimeters .

SYMBOL	DIMENSION IN MM		DIMENSION IN INCH	
	MIN.	MAX.	MIN.	MAX.
A	2.35	2.65	0.093	0.104
A1	0.10	0.30	0.004	0.012
b	0.33	0.51	0.013	0.020
c	0.23	0.32	0.009	0.013
E	7.40	7.60	0.291	0.299
D	12.60	13.00	0.496	0.512
e	1.27 BSC		0.050 BSC	
H _E	10.00	10.65	0.394	0.419
Y	— 0.10		— 0.004	
L	0.40	1.27	0.016	0.050
θ	0	8	0	8

NSOP16 (150mil)

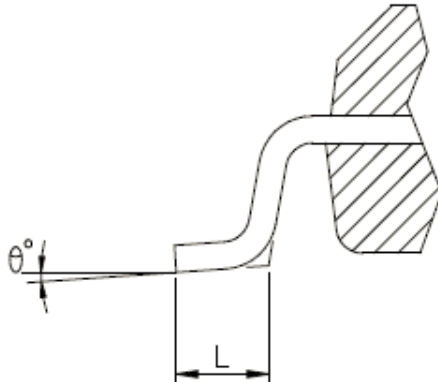
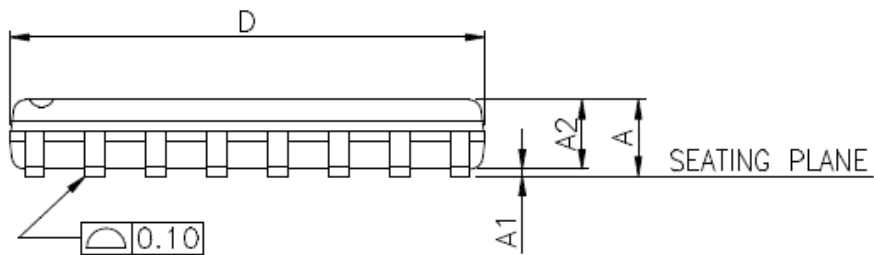
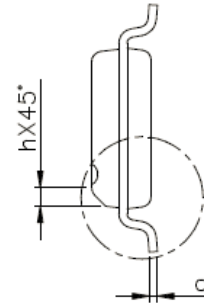
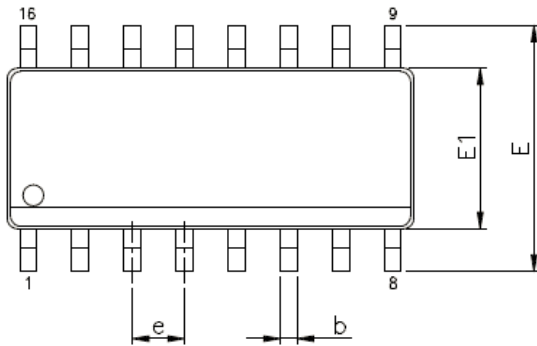

SYMBOLS	MIN.	NOM.	MAX.
A	1.51	1.63	1.75
A1	0.10	0.18	0.25
A2	1.25	1.45	1.65
b	0.31	0.41	0.51
c	0.10	0.18	0.25
D	9.70	9.90	10.10
E	5.80	6.00	6.20
E1	3.70	3.90	4.10
e	1.17	1.27	1.37
L	0.40	0.84	1.27
h	0.25	0.38	0.50
θ°	0	4	8

UNIT : mm

7. Contact Details

- **Headquarters**
4F.-1, No.9, Zhanye 1st Rd., East Dist., Hsinchu City, Taiwan (R.O.C.)
TEL: +886-3-6662888 FAX: +886-3-6662999

- **Taipei Sales Office**
4F., No.88, Baoqiao Rd., Xindian Dist., New Taipei City, Taiwan (R.O.C.)
TEL: +886-2-89111525 FAX: +886-2-89111523

- **Kunshan Sales Office**
Suite 1620, Building A, Modern Plaza, No.18 Weiye Road, Kunshan, JiangSu
TEL: +86-512-50315768 FAX: +86-512-50315798

- **Shenzen Sales Office**
Suite 625, East Block, Tian An Technology & Innovation Plaza Phase II,
Tian An Cyberpark, Futian, Shenzhen, Zip code 518040
P.R.C.
TEL: +86-755-82507658 FAX: +86-755-82507532